

AI ALARON®

B-4085

INSTRUCTION MANUAL

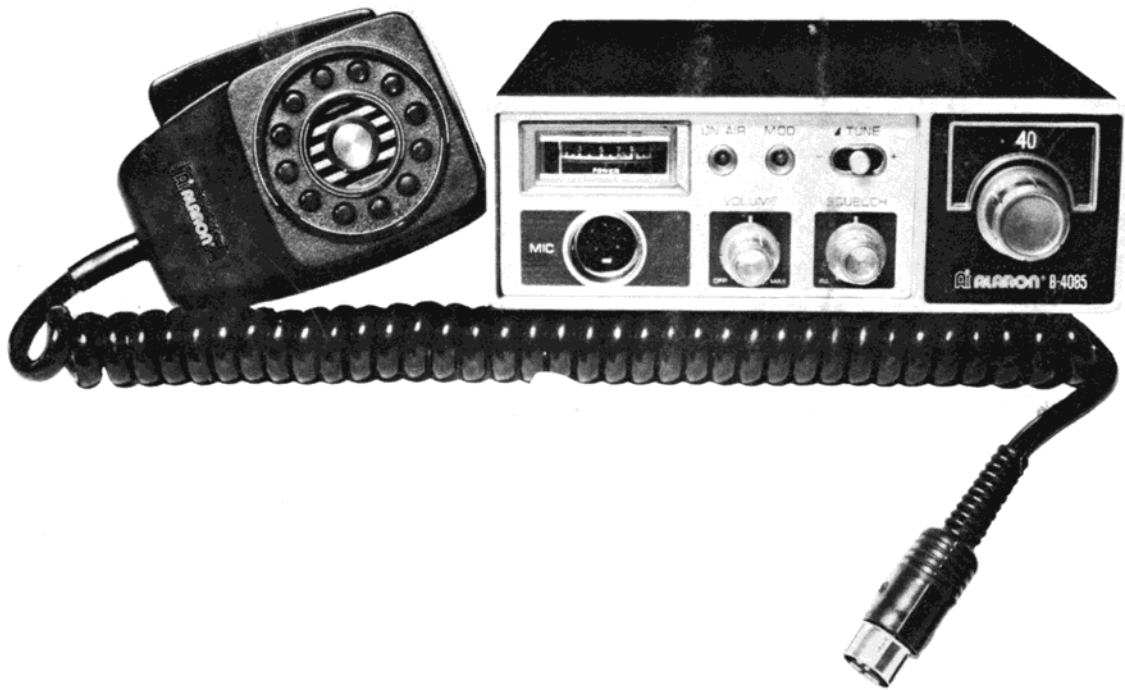

40 Channel
PLL Frequency Synthesized
Two-Way
CB Communications
Transceiver

ALARON B-4085 SPECIFICATIONS

TRANSMITTER SECTION

POWER OUTPUT.	4Watt Max(AT 13.8V DC)
EMISSION.	6A3
SPURIOUS RESPONSE REJECTION.	All harmonic and spurious suppression greater than FCC and D. O. C. requirements
MODULATION.	AM, 90 % typical

RECEIVER SECTION

CIRCUIT TYPE.	Dual conversion superheterodyne with RF stage and 455 KHz ceramic filter
FREQUENCY.	40 crystal-controlled PLL channels in the 27MHz Citizens Band
SENSITIVITY.	1.0 μ V for 10dB S/N
SQUELCH RANGE.	0-1mV
SELECTIVITY.	70 dB down at \pm 10 KHz
IF FREQUENCY.	1st IF: 10.695 MHz 2nd IF: 455 KHz
IMAGE REJECTION.	55dB
AUDIO OUTPUT.	2.5W maximum at 8 ohm load
CURRENT DRAIN.	250mA on standby [no signal]
CURRENT DRAIN (MAXIMUM).	Less than 1.5 A
ANTENNA.	Nominal 50 ohms impedance
POWER SOURCE.	Operates from nominal 12.6 volts DC, negative or positive ground system
DIMENSIONS [OVERALL].	6 $\frac{1}{4}$ " [W] \times 9" [D] \times 2" [H]
WEIGHT.	5.6 lbs

ALARON RESERVES THE RIGHT TO MAKE DESIGN CHANGES OR MODIFICATIONS WITHOUT INCURRING ANY OBLIGATION TO INCORPORATE THEM IN PRODUCTS PREVIOUSLY SOLD.

INSTRUCTIONS APPLICABLE TO TRANSCEIVERS CARRYING SERIAL NUMBER 00000001 OR HIGHER.

THE FCC REQUIRES A LICENSE BEFORE YOU OPERATE THIS TRANSCEIVER

Your ALARON B-4085 is designed to operate under FCC Rules and Regulations Part 95. Operation of this unit is not permitted until you have obtained the necessary FCC license. The Class D Citizens Band License may be obtained by any citizen over 18 years of age by filling out FCC license application form 505. You are required to read and understand the applicable FCC rules and regulations. These can be obtained from the Superintendent of Documents, Government printing Office, Washington 25, D. C., requesting Volume VI of FCC Rules and Regulations [which includes Part 95]. When you sign the application form you certify that you have read the rules and regulations. Remember courtesy on the air is the mark of A good operator. Always listen before you transmit. Choose the least crowded frequency for your communications.

TRANSMITTER IDENTIFICATION CARD

When you receive your license, you are required to fill out the Transmitter Identification card, FCC Form 452-C, which will be found with the unit. You should fill out the card as follows:

1. Fill in your call sign.
2. Fill in the name of the licensee.
3. Fill in the address where the license is located.
4. Previously answered
5. Date of license expiration should be entered.
6. Enter your signature

Affix the card to the unit.

DESCRIPTION

ALARON B-4085 is an all-transistor 2-way radio transceiver for mobile operation. A frequency synthesizer circuit provides 40 crystal controlled PLL transmit and receive channels in the 27 MHz Band, engineered for trouble-free performance. Your transceiver uses heat resistant transistors in all critical areas. Current drain on 12volts DC is exceptionally low. Operation over long periods is feasible even with your engine turned off. the transceiver may also be operated from A.C when used with an optional Power Supply.

RECEIVER

The receiver is a sensitive and highly selective dual-conversion superheterodyne type providing crystal-controlled PLL operation on all 40 CB channels. The circuit incorporates a number of features designed to provide optimum reception. The receiver incorporates an effective full-time switchable Automatic Noise Limiter in the audio stages. A ceramic filter provides sharp selectivity and high adjacent channel rejection. As a result, transmissions on adjacent channels cause minimum interference. A variable squelch control is incorporated to "silence" the receiver when no signals are being

received. The squelch circuit is adjustable providing varying degrees of sensitivity to incoming signals.

TRANSMITTER

The transmitter offers crystal-controlled operation on all 40 CB channels, 5 watt DC power input to the final RF with average modulation capabilities is possible by the use of high-efficiency Transistors and low loss components, wiring, and mounting boards. The legal limit of power for this service is provided.

POWER SUPPLY

The transceiver is ready for connection to a 12 volt DC, negative or positive ground system. DC power is provided to the transceiver by means of a fused power lead.

OPERATING CONTROLS AND FEATURES

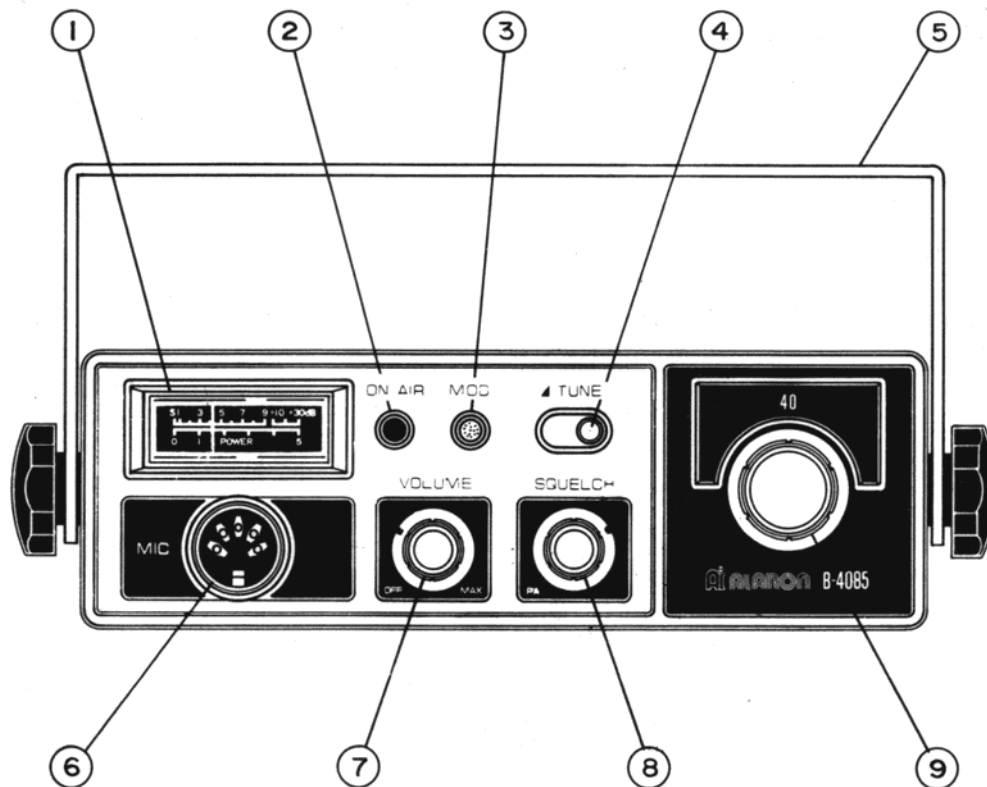

FIGURE 1

- [1] S/P-RF ILLUMINATED METER. Indicates relative incoming signal strength [top scale] and relative RF power output [bottom scale] when transmitting.
- [2] ON AIR INDICATOR LIGHT Lights up when you are transmitting.
- [3] MODULATION INDICATOR. Indicates the carrier being modulated by voice.
- [4] DELTA TUNE SWITCH. This position permits fine tuning of incoming signal during receiver mode.

- [5] MOUNTING BRACKET Bracket simplifies installation-has “quick-release” feature for removal of unit.
- [6] MICROPHONE INPUT 5 Pin socket for push-to-talk microphone.
- [7] ON-OFF/VOLUME Controls output from the built-in speaker or externa speaker connected to the “EXT SP” or PA jack [rear of transceiver]. Incorporates “ON –OFF” power switch at the extreme counter-clockwise positich.
- [8] SQUELCH CONTROL Used to quiet the receiver during absence of receive signals. Sensitivity to incoming signals is fully adjustable. In corporates PA switch at the extreme counter clockwise position.
- [9] CHANNEL SELECTOR ILLUMINATED SWITCH, Rotary switch selects one of 40 channels for transmit and receive operation.

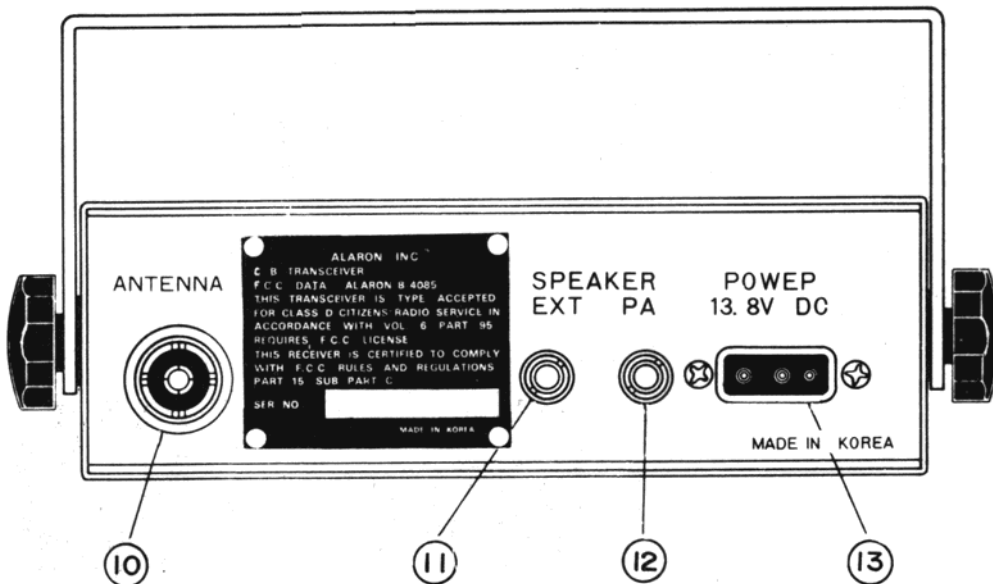

FIGURE 2

- [10] ANTENNA CONNECTION. To match antenna lead-in cable [RG-58/U or RG-8U] with PL-259 type coaxial connector.

- [11] EXTERNAL SPEAKER JACK. Impedance of any device such as headphone connected to this jack should be 8-16 ohms. Insertion of plug into jack automatically silences the transceiver internal speaker.

- [12] PA SPEAKER JACK. For Public Address [PA] operation. Horn impedance should be in 8-16 ohm range.

- [13] DC POWER SOCKET. 12 volts DC for transceiver supplied through DC power Cable to this socket.

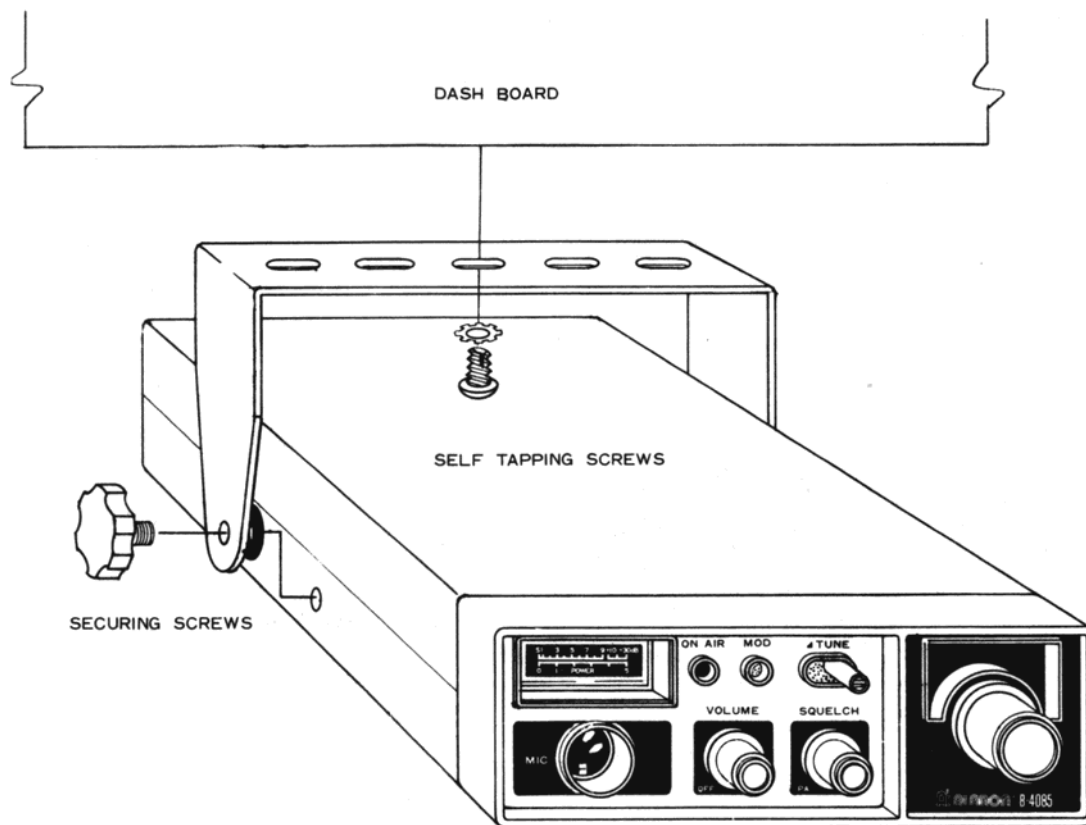

FIGURE 3. MOBILE MOUNTING

TRANSCEIVER INSTALLATION

MOUNTING

Always mount where controls are readily accessible, Unit may be mounted to the underside of the dashboard of a car, truck, etc., utilizing special bracket included with transceiver [see Figure 3]. Attach bracket to the underside of dashboard using the self-tapping screws supplied. Attach the transceiver to the bracket using the two knurled securing screws at the side.

Tilt the unit to the most convenient angle before tightening securing screws.

DC POWER CONNECTIONS

The transceiver is designed to operate from a battery source of 11.5 to 14.5 volts DC, employing either negative or positive ground electrical systems. The fused DC power cable supplied is used to make the necessary power connection to the transceiver. Red [fused] lead is connected to the positive [+] side of the electrical system and the black lead is connected to the negative [-] side of the system.

In a negative ground vehicle, connect the Red lead to the "hot" point in the electrical system [battery positive], and the Black lead to any point connected to the vehicle chassis [battery negative].

In a positive ground vehicle, connect the Black lead to the "hot" point in the electrical system [battery positive], and the Red lead to any point connected to the vehicle chassis [battery negative].

For connection to the "hot" battery side a suitable post can usually be found on the fuse block. The transceiver draws a maximum of 1.5 ampere of current, therefore you can use a terminal which supplies power to the Radio or other accessory [Use the unfused input side. The DC power cable is equipped with its own fuse]. Connection at this point will ensure DC power is automatically cut off to the transceiver when the ignition is turned off.

IMPORTANT: DC VOLTAGE AT THE TERMINAL SELECTED ON THE FUSE BLOCK MUST BE AT LEAST 11.5 VOLTS FOR PROPER OPERATION.

When you have completed the connections of the red and black leads of the DC power cable, attach the 3-pin female plug at the other end of the power cable to the matching male power connector at the rear of the transceiver. The plug can be inserted in only one direction for your convenience.

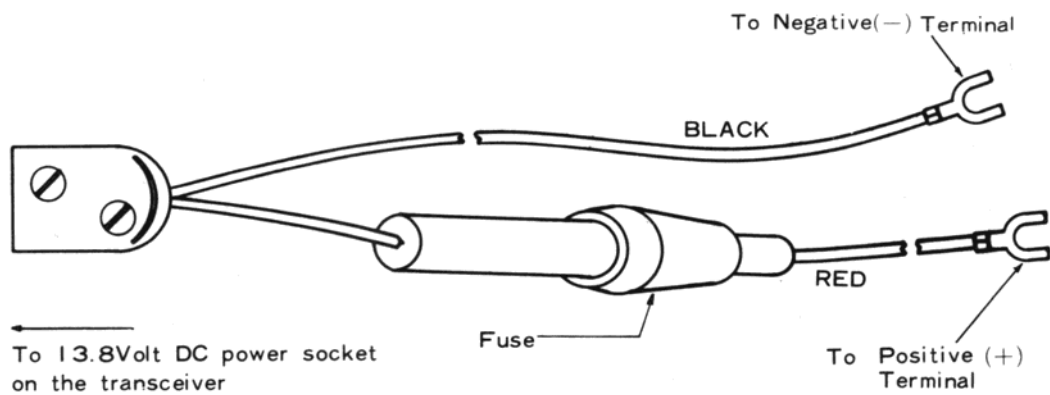

FIGURE 4. CONNECTING DC POWER CORD

ANTENNA CONNECTION

The lead-in cable from the CB antenna must be terminated with a PL-259 type male connector. Attach to the matching antenna input connector at the rear of the transceiver.

MICROPHONE BRACKET

Attach the microphone bracket provided to any convenient location.

MICROPHONE CONNECTION

Insert the 5-pin plug at the end of the coiled cord into the microphone socket.

DO NOT TRANSMIT WITHOUT AN ANTENNA CONNECTED TO THE TRANSCEIVER.

ANTENNAS

Efficient mobile operation requires the best possible radio frequency radiator or antenna. Many types are available including trunk mount, bumper mount, roof top mirror, etc. Selection is a matter of available space and personal preference. Virtually unlimited selection is available and you should consult your dealer for his specific recommendation. All good antennas are packaged complete with hardware and connecting cable. Usually no tools are required, although some mounting methods require a small hole be drilled. Remember if you have a choice generally speaking a longer antenna performs best and the higher the better.

IGNITION INTERFERENCE

Normally the suppression on modern automotive engines is adequate to prevent annoying interference to your CB transceiver. If it does not, consult your dealer who will recommend additional suppression measurements

RECEIVING

1. Select desired channel using the channel Selector Switch.
2. Rotate "squelch" control to the extreme counter-clockwise position.
3. Rotate the "VOLUME/ON-OFF" switch clockwise, to apply power. Operation will be instantaneous.
4. Set the "VOLUME/ON-OFF" switch clockwise to a comfortable listening level [approximately 1/3 setting]. The receiver is now ready to operate.

SQUELCH ADJUSTMENT

The Squelch control eliminate annoying background noise in the absence of signals. To adjust the SQUELCH control properly turn up VOLUME until background noise is heard Rotate the SQUELCH slowly clockwise until the background noise just disappears. At this point the receiver will be quiet under "no-signal" conditions, however a reasonable strength incoming signal will overcome the squelch action and be heard. As the control is advanced the squelch action is progressively increased and stronger incoming signals are needed to overcome it. To receive weak signals or to disable the squelch circuit turn the control fully counter clockwise.

EXTERNAL SPEAKER JACK

Recommended plug for the EXT SPEAKER jack is a "TINIPLUG" subminiature phone plug. The impedance of earphones or speakers connected should be 8-16 ohms. Insertion of a plug automatically silences the transceivers internal speaker.

SIGNAL STRENGTH METER

When receiving, this meter provides a relative indication of signal strength in "S" units providing a means of comparison between one received signal and another.

TRANSMITTING

Prior to operating your transmitter do the following.

1. Your Class D citizens band equipment license must be posted at the main control station location.
2. A properly executed mobile identification card, 452C, must be affixed to the mobile unit.
3. Rules Part 95 must be read and understood.

To transmit, depress the push-to-talk button on the microphone. The Red Transmit Indicator light will come on and will "flicker" slightly as you speak into the microphone. Use the microphone like a telephone speaking several inches from the face. Do not shout, use a normal speaking voice.

When you are transmitting, the receiver is silenced and reception is, therefore, impossible. In the same way, your signal cannot be heard by another station when he is transmitting---each must take turns. To receive again, simply release the microphone push-to-talk button.

INDICATING METER

In transmit position the meter gives a relative indication of antenna RF power output on the bottom power scale. As you speak, the pointer should "flicker" slightly, indicating you are modulating the RF carrier. The RF power meter will read true antenna power output when the transceiver is connected to a 50-OHM resistive load. The meter readings will not be accurate if the load is mismatched but this will not adversely affect operation if a standard good quality antenna is used.

USE AS PUBLIC ADDRESS SYSTEM

Provision has been made for Public Address [PA] operation utilizing the microphone and audio stages in the transceiver. For PA operation, use an external high-efficiency public address horn-type speaker with an impedance range of 8 to 16 ohms. Connect to the PA jack on the rear panel of the transceiver. The required plug is a subminiature phone plug, a plug is packaged in the accessory package accompanying this unit. PA volume is controlled by the receiver volume control. To switch to PA position, the squelch control must be rotated to extrem counter clockwise position until it clicks to a stop.

AVAILABLE CITIZEN BAND FREQUENCIES

Your transceiver provides operation on all available U.S. Citizens Band channels. Frequencies are listed in accompanying table.

Channel	Frequency	Channel	Frequency
1	26.965	21	27.215
2	26.975	22	27.225
3	26.985	23	27.255
4	27.005	24	27.235
5	27.015	25	27.245
6	27.025	26	27.265
7	27.035	27	27.275
8	27.055	28	27.285
9	27.065	29	27.295
10	27.075	30	27.305
11	27.085	31	27.315
12	27.105	32	27.325
13	27.115	33	27.335
14	27.125	34	27.345
15	27.135	35	27.355
16	27.155	36	27.365
17	27.165	37	27.375
18	27.175	38	27.385
19	27.185	39	27.395
20	27.205	40	27.405

TRANSCEIVER SERVICING

Transceiver has been fully tested prior to shipment and will not normally require further adjustments.

WARNING

As prescribed in Part 95.58, paragraph [e] of the FCC Rules and Regulations, the manufacturer of the transceiver is required to issue the following warnings:

1. Certain repairs and adjustments to this transceiver may be made legally only by a person in possession of a valid First or Second Class FCC Radiotelephone Operators License [or equivalent in Canada], or by a person under the direct supervision of a holder of such a license. This applies particularly to those repairs or adjustments, such as replacement of crystals and transmitter oscillator components, which might affect the transmitter's ability to comply with FCC regulations.
2. Use only approved replacement parts when servicing the transmitter. The use of a component [such as a crystal, semiconductor, capacitor, etc.] having different electrical characteristics and ratings than that originally used could result in a violation of the FCC Regulations and is therefore prohibited.

CRYSTAL CONTROLLED "PHASE LOCKED LOOP" SYNTHESIZING SYSTEM

This transceiver uses a frequency synthesizing system which employs two crystals and the PLL (phase locked loop) circuit to produce 40 transmitting and 40 receiving channels. The accompanying chart shows the operating mode.

VCO FREQUENCIES AND MIXING

CH.	TRANSMIT		CHANNEL FREQUENCY	RECEIVE			
	VCO	CRYSTAL OSC		VCO	FIRST IF	CRYSTAL OSC	SECOND IF
1	16.543	10.422	26.965	16.27	10.695	10.24	455
2	16.553	"	26.975	16.28	"	"	"
3	16.563	"	26.985	16.29	"	"	"
4	16.583	"	27.005	16.31	"	"	"
5	16.593	"	27.015	16.32	"	"	"
6	16.603	"	27.025	16.33	"	"	"
7	16.613	"	27.035	16.34	"	"	"
8	16.633	"	27.055	16.36	"	"	"
9	16.643	"	27.065	16.37	"	"	"
10	16.653	"	27.075	16.38	"	"	"
11	16.663	"	27.085	16.39	"	"	"
12	16.683	"	27.105	16.41	"	"	"
13	16.693	"	27.115	16.42	"	"	"
14	16.703	"	27.125	16.43	"	"	"
15	16.713	"	27.135	16.44	"	"	"
16	16.733	"	27.155	16.46	"	"	"
17	16.743	"	27.165	16.47	"	"	"
18	16.753	"	27.175	16.48	"	"	"
19	16.763	"	27.185	16.49	"	"	"
20	16.783	"	27.205	16.51	"	"	"
21	16.793	"	27.215	16.52	"	"	"
22	16.803	"	27.225	16.53	"	"	"
23	16.833	"	27.255	16.56	"	"	"
24	16.813	"	27.235	16.54	"	"	"
25	16.823	"	27.245	16.55	"	"	"
26	16.843	"	27.265	16.57	"	"	"
27	16.853	"	27.275	16.58	"	"	"
28	16.863	"	27.285	16.59	"	"	"
29	16.873	"	27.295	16.60	"	"	"
30	16.883	"	27.305	16.61	"	"	"
31	16.893	"	27.315	16.62	"	"	"
32	16.903	"	27.325	16.63	"	"	"
33	16.913	"	27.335	16.64	"	"	"
34	16.923	"	27.345	16.65	"	"	"
35	16.933	"	27.355	16.66	"	"	"
36	16.943	"	27.365	16.67	"	"	"
37	16.953	"	27.375	16.68	"	"	"
38	16.963	"	27.385	16.69	"	"	"
39	16.973	"	27.395	16.70	"	"	"
40	16.983	"	27.405	16.71	"	"	"
			IN MHz				

INSTRUCTIONS-FOR ALIGNMENT

PROTECTIVE COVER

Turn Transceiver over (speaker grille upward), and remove the facing chassis cover (2 screws each side). The speaker is connected by two leads to the main chassis so remove cover with care.

Tune up procedure for power level

For this output power level tune up procedure, it is assumed that the PLL frequency synthesizer is functioning properly. The entire PLL circuitry (including two crystal oscillators, VCO, frequency dividers, low pass filters and the phase detector) is sealed in metal shield. The PLL section alignment procedure will be explained after-ward.

Set DC power supply voltage at 12.6 volt DC. Connect an RF wattmeter (50 ohm) to the antenna connector.

Set transceiver to channel 19 (27.185 MHz).

Refer to interior parts location drawing in instruction book for the following adjustments.

1. Depress microphone button and adjust cores of L301, L302, L303, L304, L305, L306, L307, and L308 for maximum on the wattmeter.
2. Check output power on all channels. If not equal, readjust L302, L303, L304, and L402.
3. Adjust L307, and L308 for optimum maximum wattmeter output.
4. Adjust RV 103 for reading on transceiver power meter equal to indication on the wattmeter.
5. At factory C314 (nominal value of 82 pfd) is selected for maximum RF power level at 3.75 watts with 13.8V DC power supply.

PLL circuit alignment procedure :

1. Set transceiver at Transmit mode.
2. Connect oscilloscope DC probe to T.P.1
3. Adjust L403 and observe the DC level swing btw zero volts to 8 VDC. Then set the level at 2VDC when channel selector is set at channel 40.
(Note when channel selector is switched to 1. the level will jump up to about 5-6 VDC.)
4. With frequency counter measure VCO frequency at P408 against the chart.
As an example, the channel 1 Transmit VCO should be 16.543 MHz. When changed to channel 1 Receive mode, the VCO frequency will be 16.27 MHz.

Receiver alignment procedure

Set volume to maximum. Selector to channel 19.

455KHz IF alignment

1. Connect AC VTVM to speaker terminals.
2. Connect signal generator to cathode of D109
3. Set signal generator to 455KHz \pm 0.5KHz
4. Apply power to unit and adjust signal generator output to produce a reading of 0.5 volts on the AC VTVM.
5. Adjust L105, L106 and L107 for maximum output on VTVM.

NOTE : Reduce output of signal generator as necessary to keep VTVM reading around 0.5 volts

FIRST I F ALIGNMENT, 10,695 MHz

1. Connect AC VTVM to speaker terminals.
2. Connect signal generator to the base of transistor Q102.
3. Set signal generator to 10.695 MHz [± 1 KHz].
4. Adjust L103 and L104 for maximum output as read on VTVM. Reduce signal generator output as necessary to keep the VTVM reading around 0.5 volts.

RF ALIGNMENT

1. Connect AC VTVM across speaker terminals.
2. Connect signal generator to antenna connector.
3. Set signal generator to 27.185 MHz, modulated 30% with a 1 KHz tone. Set signal generator output to $10\mu\text{V}$.
4. Set transceiver to channel 19 and vary signal generator frequency around 27.185 MHz to produce a maximum reading on the AC VTVM. Leave generator at this point.
5. Adjust L101, L102 and L401 to produce maximum output on AC VTVM.
6. Reduce generator output to approximately $1\mu\text{V}$. Adjust L101, L102, L103, L104, L105, L106, L107 and L401 for maximum reading on VTVM. Repeat until no further improvement noted.
7. Adjust RV102 for "S-9" reading on the transceiver meter with $100\mu\text{V}$ signal input.
8. Squelch Adjustment. Adjust input signal to 60 dB [1mV] from signal generator, and turn squelch control full clockwise; adjust RV101 until signal just breaks through.

RETURNING THE UNIT FOR SERVICE

In the event repair is necessary please return unit to the store from which it was purchased. If necessary to return to our service head quarters, pack your transceiver extremely carefully. Use UPS prepaid. Please enclose a description of difficulty experienced as well as when and where unit was purchased.

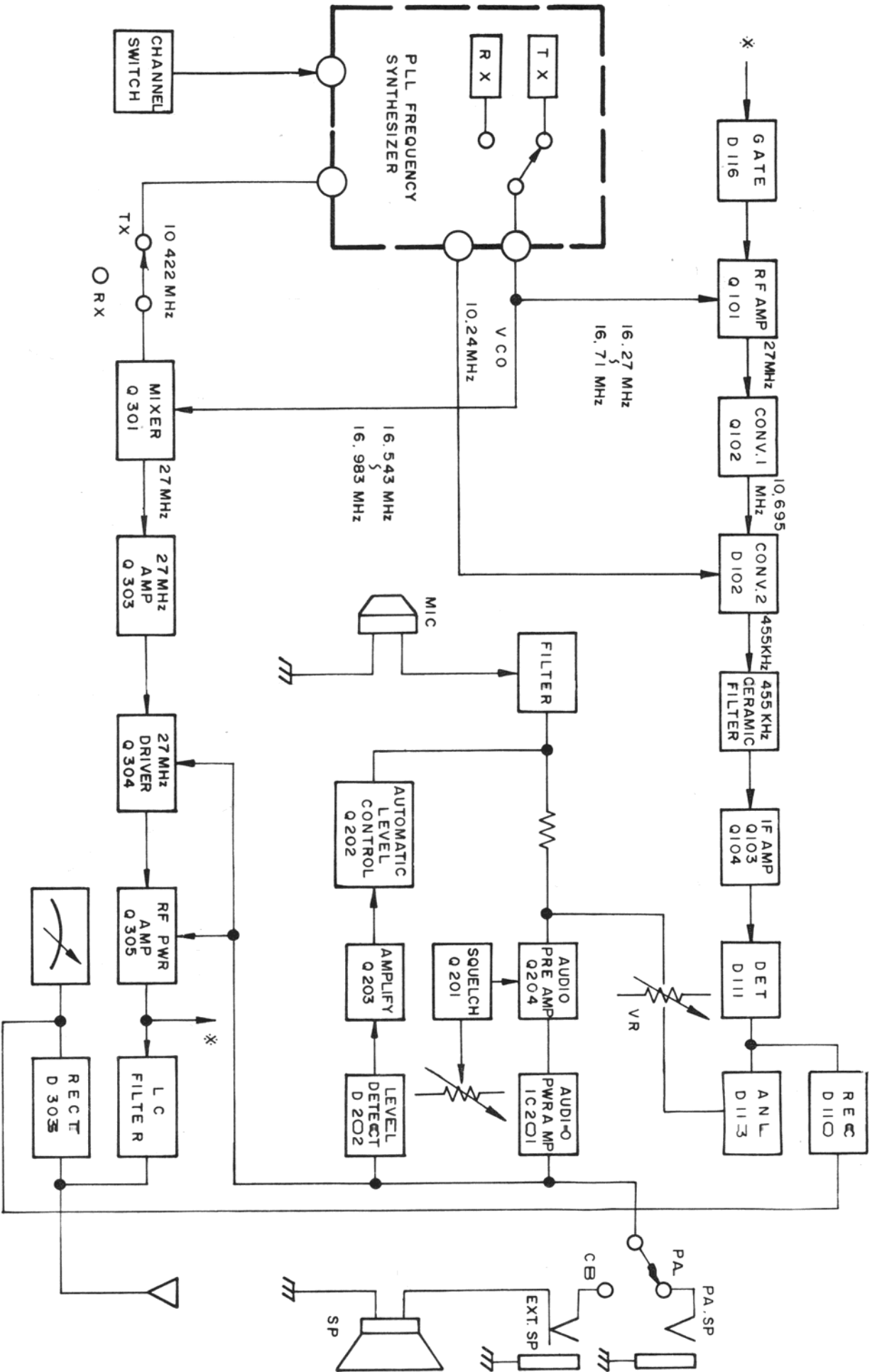

FUNCTIONAL BLOCK DIAGRAM

